

EWS-DR/ EWSi-DR

EN

2 Doors/2 Readers Access Control Unit

INSTALLER MANUAL

1. WIRING

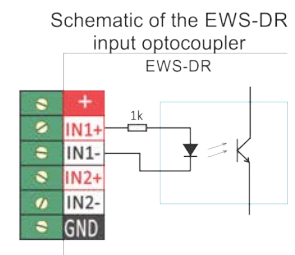
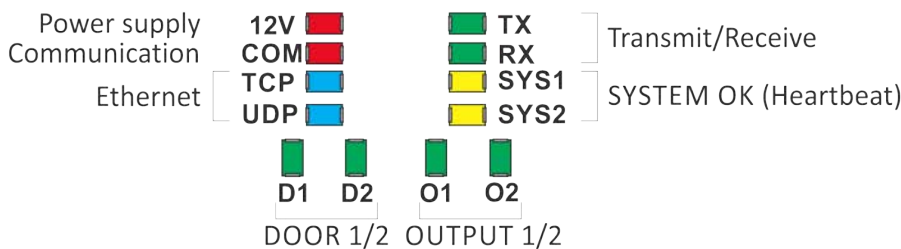
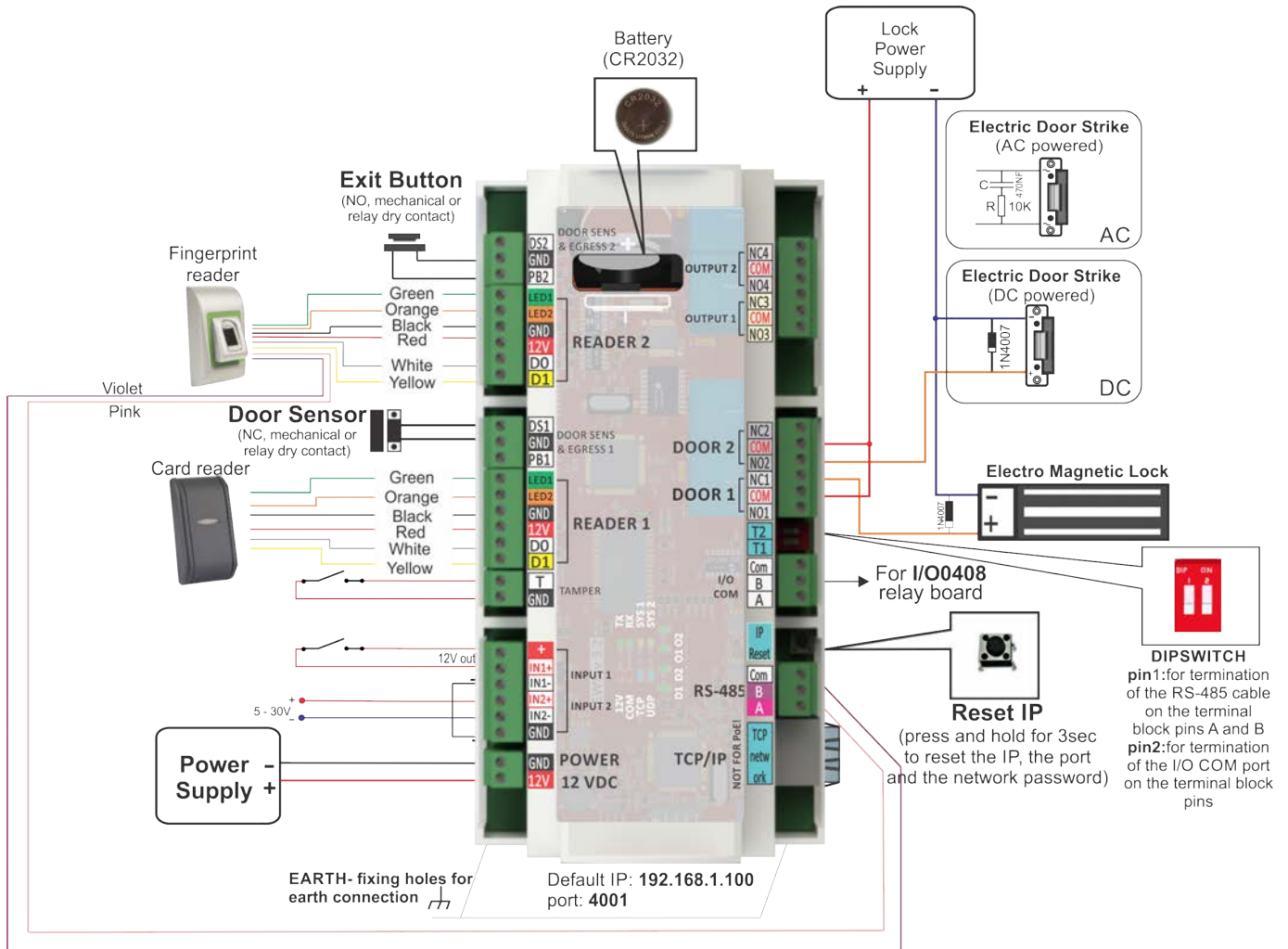

2. SPECIFICATIONS

Power Supply:	12VDC
User/Event capacity:	1000/30000, 4000/24000, 8000/16000, 12000/8000 or 15000/2500, configurable by software
Communication:	EWS-DR -RS-485, EWSi-DR -RS-485 and TCP/IP
Door relays:	2 (250 VAC, 10A)
Programmable Outputs:	2 (250 VAC, 10A)
Readers:	2
Programmable Inputs:	2, optocoupled, ON level 5-30VDC (3-28mA)
Door sensors:	2
Exit Button Inputs:	2
Wiegand interface:	Programmable (8 to 128bit), 32databits, 4 parity bits
Environment temperature:	0 - 45 C
Humidity:	0-80%, non condensing
Consumption:	EWS-DR 200mA, EWSi-DR 250mA (without readers)
Fuse protection:	1A thermal fuse for total consumption of the controller and readers.

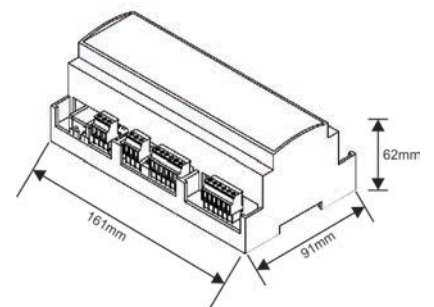

v.b2

3. INSTALLATION

1. Connect the devices according to the connection diagram above.
2. Use the diodes provided when the door lock is DC powered or the capacitor with 10K resistor when the lock is AC powered.
3. Use the Dipswitch pin1 for RS-485 tuning.
4. Insert the battery provided with the hardware kit.
5. Connect the power.

4. COMMUNICATION

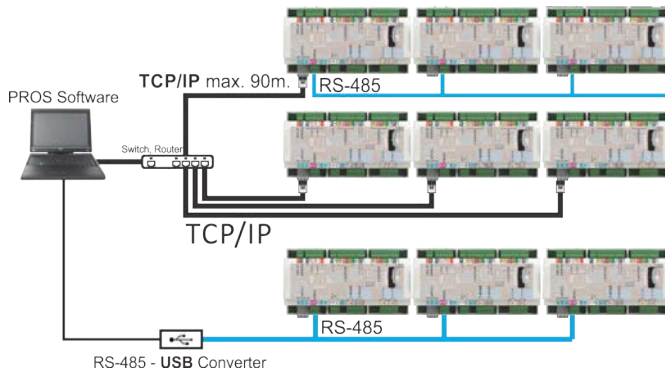

5. MOUNTING THE PCB

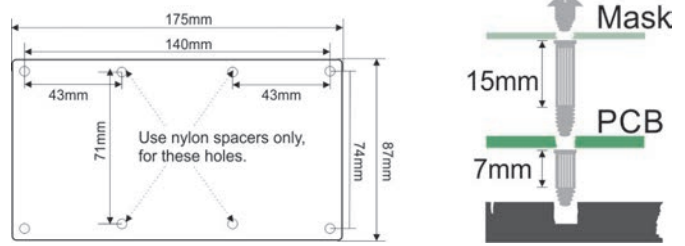

PCB can be mounted directly on the panel. In this case, use provided spacers for fixing and printed screen for protection.

6. RS-485 TUNING

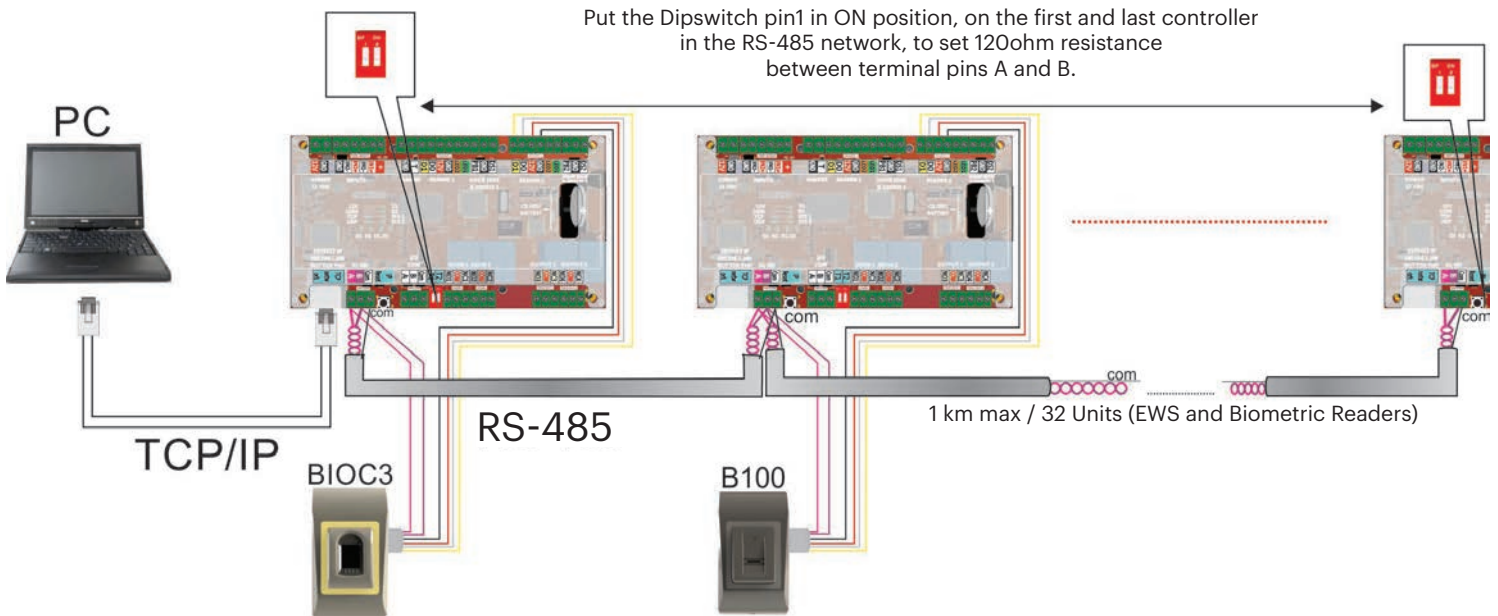

IMPORTANT NOTE:

- The RS-485 Communication Line must be made in daisy chain, NOT in a star type configuration.
- The cable must be twisted and shielded. Connect the EARTH to the shield.
- Connect the COM to each unit in the RS-485 line.
- Terminate both ends of the line with 120 Ohm resistor. If end of line is EWS-DR, use built in resistor (120 ohm) by turning the Dipswitch pin1 ON.

6. RS-485 TUNING

With PROS CS:

The default IP of the controller is **192.168.1.100**

To change the IP of the EWS controller:

1. Connect the EWS controller directly to the PC.
2. Change the IP of your PC to 192.168.1.200
3. Go in the Software and in the hardware window, **right click** on the **Portals** item, then select **Search Network Portals**. When the **Search portals** window is opened, hit **Search**.

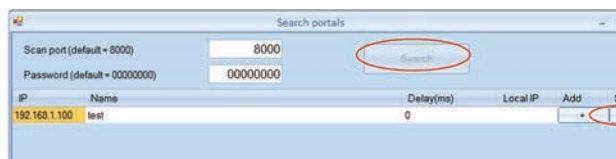
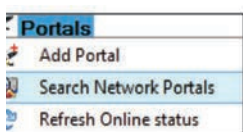

4. Click on the **"Setup"** button.

Setup Portal window is opened, and now you can set values for the parameters in the portal setup. Further you have the parameters of the setup explained.

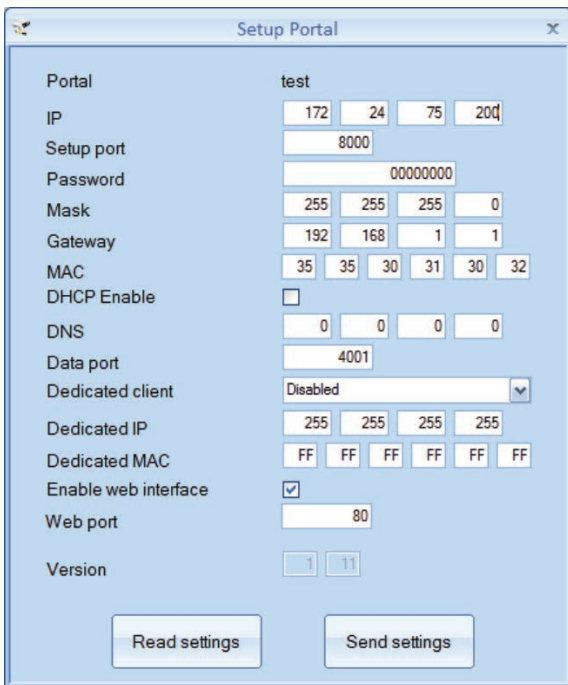

IP: Portal IP address.

Setup Port: Used for searching the portals of the network.

Password: For searching and configuring the portals.

Mask: IP Mask.

Gateway: Network Gateway.

MAC: Mac portal.

DHCP enable: It is recommended that DHCP is disabled and fixed IP value is used.

DNS: Domain name server. Recommended to keep zeros.

Data port: Port value for communication between software and devices (controllers, readers) connected to the portal.

Dedicated client: If enabled portal will connect only with software on computers that are matching the dedicated IP or dedicated MAC value. This parameter affects only communication between server software and portal. Computers that are running client software are not affected, as client software is connected only to server software and not with portals.

Dedicated IP: Valid if dedicated client is enabled.

Dedicated MAC: Valid if dedicated client is enabled.

Enable web interface: If enabled, portal configuration can be done by web browser using IP and Web port as an address.

(ex. If the port IP is 192.168.1.100 and Web port is 80, the web address for setup is <http://192.168.1.60:80>)

Version: Firmware version of the portal. If newer version is available, it will be distributed with the latest release of the access control software.

5. Change the portal IP address, and press **Send settings**.

6. Put back the IP of your PC to the previous IP address.

With Web browser:

- Change the IP of your PC to 192.168.1.200
- Connect the EWS controller and type in the browser 192.168.1.100 (username: admin, password: 00000000) and change the IP from there
- Put back the IP of your PC to the previous IP address

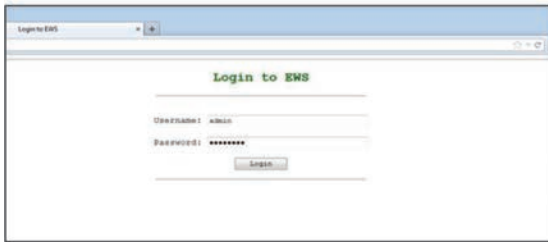

7. ADDING EWS(I)-DR CONTROLLER IN THE SOFTWARE

In order the controller to communicate with the software, the controller must be added in the software with its Serial Number. The serial Number is written on the controller itself, but it can be also searched when the controller is connected to PC.

1. Right click on Portals and select "Search Network Portals"
2. The Software will find all the IP's of the controllers that are connected to the network
3. Click on "Add"
4. Right click on the newly added portal and "Search devices" for Controllers. The software will find all the Serial Numbers of the controllers that are connected under that IP address.
5. Click on "Add New" and the controller will be added. Put a name for the controller and "Save and Exit". From then on the controller should be on line.

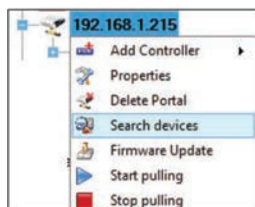
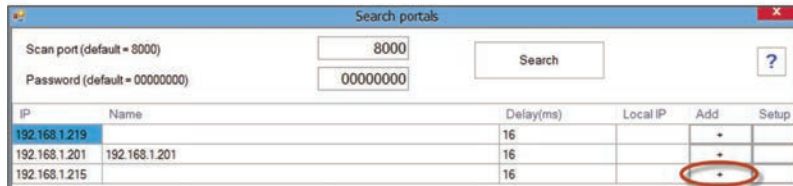
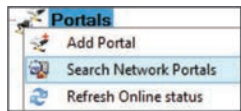

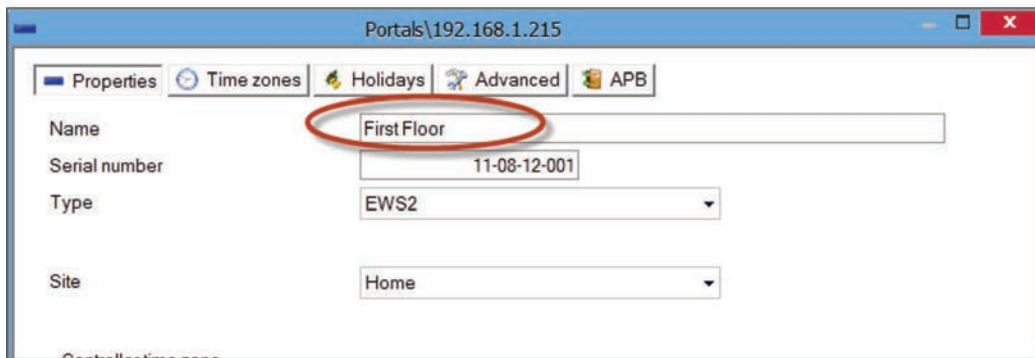
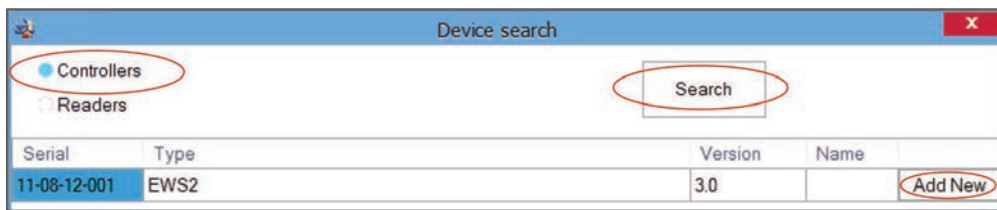

Time	Portal	Controller	Reader	Door	Event
3/6/2017 19:33:12	192.168.1.215	11-08-12-001			Controler Online

Note: If the Controller/Portal can not be added automatically by search option, add them manually.

For any other feature, see the HELP File located within the software itself

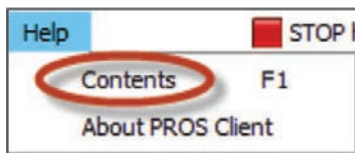

8. TROUBLESHOOTING

1. Reader is not reading the card.

- Check the power supply at reader. If the voltage is low use additional wires for power supply.
- Check the connection of the wires in EWS-DR reader terminals.
- Check if the card type match the reader or the readers card type setup.
- Check for correct wiring.

2. Reader is reading the card, but no reaction from the controller or access event in the software.

- Check in software if readers Wiegand setting match the reader Wiegand output.
- Check if cable length is within the specifications of the reader. If reader is working with short cable then the problem is voltage drop on power supply lines. In this case use free wires as additional power supply lines for the reader. If you have only one free wire use it to improve the 0V line.

3. Communication via RS-485 line is inconsistent or non-existing (in the software, controller is switching online/offline status).

- Check if A and B lines are correctly connected at all terminals/devices.
- Check if one of the RS-485 lines is disconnected at some point.
- Check termination configuration of RS-485 line in all devices.

4. Controller loses time and users after mains power failure.

- Replace the controller coin battery (Cr2032).
- Always use power supply with battery charger and battery of at least 4 Ah.

5. Software cannot connect to controller via TCP.

- Make sure there is no other device with the same IP address in the network.
- Make sure there is no other software communicating with the controllers.
- Check with the WEB interface of the EWS-DR if the settings are correct.

6. Searching portals in software shows only some or none of the portals.

- In the software under settings/system parameters disable the item "use default PC network interface only".

7. Controller does not perform some options configured by software.

- Check the controller firmware by right-clicking on the controller icon and selecting "Check version item". Upgrade the firmware by right-clicking on the controller icon and select "Firmware upgrade item".